



Scientific technological Center

Via Bovio 6 – 28100 Novara - NO - Italy

Tel +39 0321697200 - Fax +39 0321 688515 - Email: info@etneo.com

www.etneo.com

FUME PURIFYING & FILTERING SYSTEM MODEL Q1.2 & Q2.2

ISNTRUCTION MANUAL

Announcements

1. Ban use in suction occasion with open fire, in case breaking out of fire.
2. Ban use in suction occasion with hot flake, in case breaking out of fire.
3. The unit must be placed straight up. No slantwise placing or converting the origination for protecting the unit from damage.
4. When change filter, please check if the rubber frame put smooth or not, if not, can arouse air leakage .
5. Before the first time use, please take out the foam which under the main machine.
6. When use hasp button, please tamp down head cover, and then fixed the hasp button, otherwise can damage it.

1. Summary

The unit is a Fume Purifying & Filtering System for cleaning of both particles and gases. The unit is double fuming arms design and during the process of soldering, laser marking, laser carving, printing etcetera, to be used at filtrating the harmful substances, such as hydrocarbon, cyanide etc.

For good efficiency, it designs a Triple-filter system: pre-Filter, middle filter and main filter which including HEPA (high efficiency) filter and gas filter. The pre-filter with large area ASHRAE and the middle filter can filter the bigger powders for prolonging the main filter's life. The HEPA cleans the gas and powders filtering from the pre-filter and then output them to the gas filter, which with the carbon and other chemical combination, filters off the deleterious substance and then outputs the clean air.

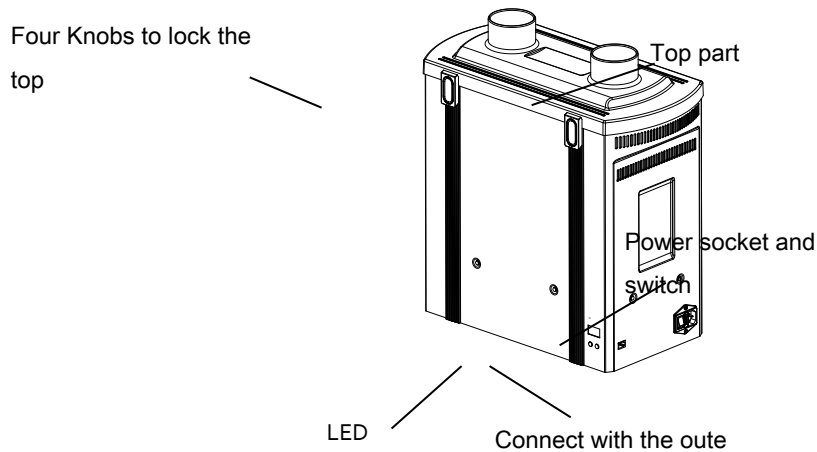

2. Characters

1. It is easy to install and not lay pipelines. Triple-filter design. Remove hazardous substances to ensure health. Pre-Filter and Main Filter can be replaced separately for prolonging the filter's life and cutting down the cost.
2. Circulate air filter type, avoid let cool air/heat air indoor to outdoor, save energy really, and fit environmental protection requirement.
3. Increase power DC brushless motor, wind large, with suspension function, extend life.
4. Low noise design.
5. Double fuming arms design, the airflow and arms both are adjustable.
6. the diameter of directional air hose can input, procedure automatic adjustment relevant parameter.

3. Specifications Q1.2 & Q2.2

Voltage:	230V AC
Power:	120W / 200W
Qty of Arms:	1 / 2
Airflow:	140m ³ /h / 250m ³ /h
System Airflow (Including Filter):	120m ³ /h / 2*100 m ³ /h
Filtering Efficiency (0.3um):	99.97%
Arm Length:	φ75mm×1500mm
Stationary Pressure:	2400Pa / 900Pa
Noise:	60dB
Size (HxDxW) :	420×230×430mm / 470×230×500mm
Weight:	13.4kg / 14.2kg

4. Operating instructions

Warn:

The unit must be placed straight up. No slantwise placing or converting the origination for protecting the unit from damage.

Note:

- Please take out the foam under the main filter before firstly using the unit.
 - It must press the top part tightly and then fasten the knobs to lock the top. Or else, it may cause damage to the knobs.
1. Connect the unit to the power socket and switch on the power supply. Adjust the fuming arms according to the different working occasion, the unit can work and purify the air.
 2. Connect the outer keyboard with the unit. Adjust the airflow-adjusting knob to select suitable grade. Bigger airflow will have better absorbing ability. Suggest use the unit with the bigger airflow.
 3. It can adjust the airflow by the outer adjusting key and when turning off.

5. Maintenance and replacement of filter

5.1 Trouble shooting

1.Phenomena: the LED clockwise displays circularly “□” and the unit alarms, the fan still work but the airflow is small.

Reason: it may be the inlet of the fan has been blocked about half hour or may be the main filter has in no effect.

Check: turn off the power switch, take up the top and check whether the outlet has been block and clean the other thing if necessary. Turn on the power switch and check the unit, if it is still block and it should change the filter.

2.Phenomena: the LED displays “OFF” and “ERR” by turns and the unit alarms, besides, the fan and motor stop work.

Reason: it may be something wrong with the fan or the circuit.

Check: turn off the power switch and then turn on again, if it cannot work in gear and please check the fan.

3.Phenomena: the LED anticlockwise displays circularly “□” and the unit alarms, but the fan still work.

Reason: it may be the unit has worked up to the upper limit time.

Check: turn off the power switch, and then switch on the unit, enter to the menu setting and clear the work time.

5.2 Parts Maintenance and Changeable

1. The fuming arm should be often clean.
2. The pre-filter system should be often changed.
3. The filter must be changed when the LED circularly displays “□” clockwise.
4. When the unit alarms, check the hose (fuming arms) and nozzles, clean if necessary. If the suction is deficient after cleaning, change the main filter.
5. When changing the main filter, turn off the power supply and loosen the 4 knobs on the sides of the unit. Lift the top, prefilter and middle filter straight up and put aside. Pull the main filter straight up.
6. Replace a new main filter and re-assembled it as the reverse order. Make sure the inlet to the fan fits to the connection in the bottom of the filter and that the new filter has the right side up.
7. Mark with the date of change when changing a new main filter.

 Note:

- The two sides of the pre-filter are different. When changing the pre-filter, the dense side is to the filter and the other side is to the inlet.
- After the unit has worked up to up-limited work time, it must clean it as zero, or else, the unit will alarm.
- The rubber casing must be level placed with the top edge of main filter, or else, it cannot airproof and will reduce the suction.

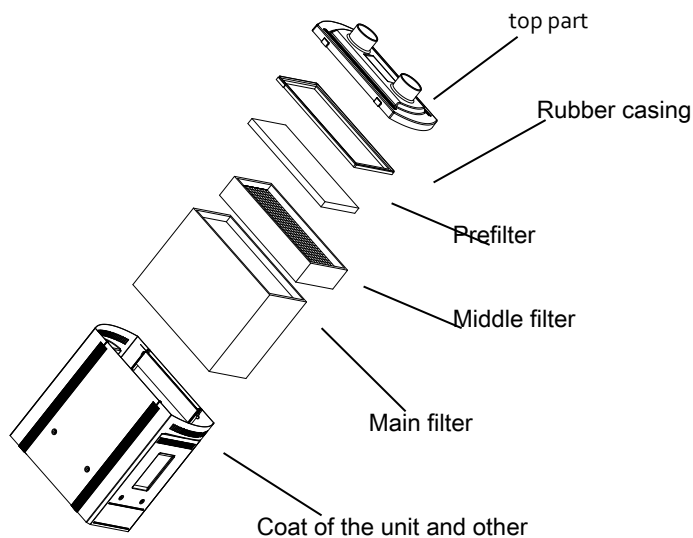

- Changing directional air hose
- When change the different diameter directional air hose, must input the diameter, method as follow:
- In the start state, (air rate is 10) ,press ▲ and ▼ key the same time, show“---” , the hundred digital flash, press ▲ key to input value 6 ,press ▲ and ▼key

affirm, show "6--" , the decade digital flash, press ▲ key input digital 6, press ▲ and ▼ key affirm, show "66-" , press ▲ key input digital 0, press ▲ and ▼ key affirm, the password input end. (the password is 660)

- After the password input , LED display the digital is the diameter of the current directional air hose, press ▲ or ▼ key to change the digital, have two digital can select 75 or 25, after select the digital , press ▲ and ▼ key affirm, after the digital be selected flash two times, LED show air rate.